



Vehicle Engine Control System Using Arduino Uno

Neenu.P.A , P.Subbaiah

Dept. of ECE, Agni College of technology Chennai, Tamilnadu, India

ABSTRACT:

Most of the accidents takes place due to reaction time of driver. The reaction time or response time is the time taken by driver to respond from observing the hurdle to applying the brakes which makes vehicle comes to rest. 53 road accidents are occurring in every hour. 24% of the accidents occurs because of drunk and drive activities. In order to avoid these accidents we design a vehicle engine control system using Arduino UNO in embedded system domain by using three sensors. The sensors used for this project is the PIR sensor, Alcohol sensor, Ultrasonic sensor. PIR sensor is used to detect the motion of the object by IR radiation. Alcohol sensor (MQ135) is used to detect the drunken drivers. An ultrasonic sensor is used to detect the obstacles and measure the distance. A living beings move in front of the vehicles.

KEYWORD:

Engine control, detection, accident, IR radiation,Alcoholic concentration, distance.

I.INTRODUCTION:

The combined unit of hardware and software constitute an “Embedded system” which is integrated together to build a system that helps in design goals like speed and efficiency. The main advantage of embedded systems is the flexibility to choose desired hardware and software components to design the desired system which performs the needed task. This paper is based on the above mentioned merits of the embedded system.

There is a necessity to reduce the vehicle accidents because, now a day’s road accidents are more frequent to occur. These accidents cause more damage to vehicle and serious injury or even death of passengers and drivers. Most of the accidents occur due to the reaction time of driver. This paper is to reduce the accidents and to reduce the drunken drivers. For that three sensors are used namely PIR sensor, Alcohol sensor, Ultrasonic sensor. This project is done with Arduino. Arduino coding is needed for sensing the moving objects, obstacles and alcohol by using arduino software. Arduino UNO is used in this project. ATmega328 processor is used in this board.

The objective of this project is to avoid the road accidents by using ultrasonic detector and PIR sensor. Also, reduce the activities of drunken drive by using alcohol detector. PIR sensor is an electronic sensor that detects the motion of the objects, by measuring the level of IR radiation. This principle is used to detect movable object in front of the vehicle. Detected signal will be send to the controller unit, according to pre burnt code in arduino.

Alcohol sensor (MQ135) is used to detect the drunken drivers. If the alcohol consumed by the drivers exceeds the limit detected by sensors automatically the engine will be turned off. Ultrasonic sensor is used to detect the distance of objects behind and ahead from our vehicle. This detected signal reflected to the buzzer according to the pre burnt code in arduino and once the buzzer on, the vehicle speed will

be reduced by the driver. These techniques will make the journey smooth and comfortable. In this paper, Section II contains problem analysis and preliminaries of this paper. Section III contains the program analysis to overcome the problems. Section IV contains the sensor analysis. Section V contains advantages of vehicle engine control system and Section VI contains conclusions.

II. PROBLEM STATEMENT AND PRELIMINARIES

Vehicle engine control system aids to avoid the accidents occurs in only one way by using single sensor. Still we have a lot of problems to avoid the accidents. Hence we propose a vehicle engine control system to avoid the accidents in multiple ways by using three sensors. In this paper, Arduino UNO is used as controller unit. An ultrasonic sensor is used to detect the obstacles and to measure the distance. An alcohol detector is used to detect the alcohol concentration on our breath. We combined these three sensors into one application. PIR sensor is an electronic sensor. It is used to detect the motion of the objects by IR radiation. If the PIR sensor detects any moving objects (human, animals) in front of the vehicle, detected signal will be send to the controller unit, according to pre burnt code in arduino to reduce the speed of the vehicle. Maximum detecting range of PIR sensor is from 5m to 12m. alcohol sensor (MQ135) is used to detect the drunken drivers, an Ultrasonic sensor is used to detect the distance of the objects by using buzzer sound and speed will be reduced by the drivers. These all functions can be controlled by the relay drivers. Transformer and rectifier are used as a power supply to arduino UNO.

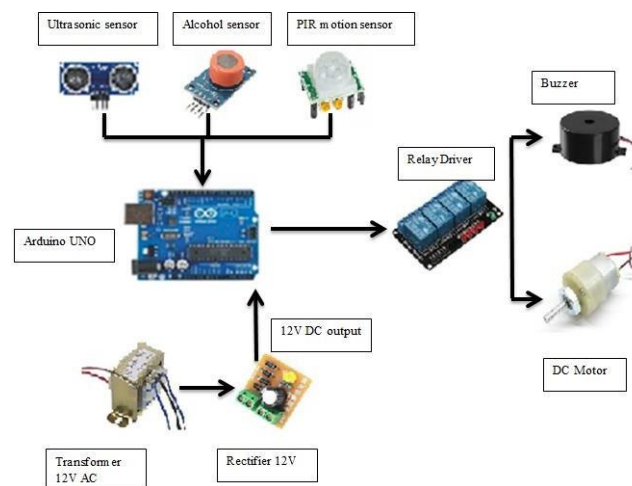

Fig Implementation of proposed system

III. PROGRAM ANALYSIS FOR IMPLEMENTING PROBLEM

In this paper, we implement a program for avoid the problems. Decision making algorithm is used to implement the program to avoid the accidents. Three sensors program was done in this paper and we combined these three sensor programs into single program to avoid the accidents in multiple ways at a time. This program starts from alcohol sensor implementation. If the alcohol concentration detected by the alcohol sensor in the vehicle steering, the vehicle won't start, automatically the engine turned off. Else, the vehicle gets started. If any other vehicle is near to our vehicle, there is a possible to occur accidents. At that time the vehicle signal is detected by ultrasonic sensor and it gives the intimation to both vehicle drivers to reduce the speed of the vehicle by buzzer sound. So according to the program, if any vehicle behind and ahead to our vehicle the buzzer sound happened otherwise the buzzer sound is not there. If any moving object (human, animal) crossing ahead of our vehicle, motion of the object

is detected by PIR sensor. Then automatically the engine turned off. Else, the engine won't turn off. This is the algorithm we done in this paper. Decision making algorithm is like,

If (condition)

```
{  
Statements;
```

```
}
```

Else

```
{  
Statements;
```

```
}
```

IV.SENSOR ANALYSIS

In this section, We mentioned the sensing range and some details about PIR sensor, Ultrasonic sensor and alcohol sensor.

PIR SENSOR

PIR sensor (Passive Infrared Sensor) is used to detect the motion of the objects by IR radiation. PIR sensor detection range is between 5m to 12m. it is made up of a pyroelectric sensor, which can easily detect the level of IR radiation from the moving objects like human and animals. PTR sensor is mostly used in home appliances. It can works from 3.3V to 5V DC supply. PIR sensor is more complicated than other sensors.

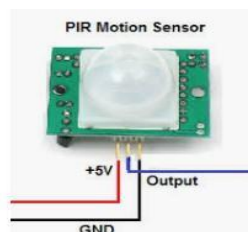

Fig 3 PIR sensor [6]

ULTRASONIC SENSOR

Ultrasonic sensor is used to measure the distance.



Fig 4 Ultrasonic sensor [7]

It uses the same principle of bat. Ultrasonic sensor can work by emitting sound wave at a high frequency. It uses transducers to send and receive ultrasonic pulses. Distance calculating formula for ultrasonic sensor in cm,

V.ADVANTAGES OF VEHICLE ENGINE CONTROL SYSTEM

The main advantages of vehicle engine control system are, to avoid the accidents and to reduce the drunken driven activities.

Combination of three applications in system will avoid the accidents occurs in multiple ways.

Adding of PIR sensor can detect edges of an area to covers the motion objects to avoid accidents.

VI.CONCLUSION

In this paper, the system have proposed the vehicle engine control to avoid accidents in multiple ways by using arduino uno, PIR sensor, Ultrasonic sensor, Alcohol sensor . Whenever the any moving object passes, the detection get sensed by PIR sensor and send the signals to the controller unit and the engine will be turned off. If the driver is drunk, the car speed will be automatically reduced by using alcohol sensor. The ultrasonic sensor detects objects' nearby the car and once it detects, a buzzer sound will produce. Based on that driver can control the speed of the vehicle. So we combined these three applications in one system. By implementing this system in the vehicle, a safe journey is possible, which would decrease the accidents and also reduces the accident rate by reducing the speed of the vehicle automatically.

REFERENCES

- [1]Anand kumar, N.Anusha, B.Sai Srinivasa vara prasad – “Alcohol detection using IoT”, Computer science engineering, Sathyabama university, Chennai, International Conference on intelligent computing and control, 2017
- [2]Md. Symum Rezwana, Md. Anik Islam, Md. Mahmudul Ismail, Md. Rakib Hasan – “VEHICLE BREAKING SUPPORT SYSTEM using ARDUINO MEGA, Faculty of Engineering ,Electrical and Electronic Department, American International University-Bangladesh, April -2018.
- [3]Prithvi Nath Saranu, Abirami.G, Sivakumar.S, Seetha.J, Arul.U, Ramesh kumar.M- “Theft detection using PIR Sensor”, Department of computer science engineering, Dhanalakshmi college of Engineering, Chennai, 4th international conference on Electrical Energy Systems,2018.
- [4]N.C. Basjaruddin, K. Kuspriyanto, S. Suhendar, D. Saefudin, and V.A. Azis – “Hardware simulation of automatic braking system based on fuzzy logic control”, Journal of Mechatronics, Electrical power and Vehicular Technology, Volume 7,no. 1,pp.1-1, Jul- 2016.
- [5]N.Anju Latha, B. Rama Murthy,, K.Bharath Kumar-” Distance sensing with Ultrasonic sensor and arduino”, Department of Instrumentation, Sri Krishnadevaran University, Anantapur,A.p.,India,Volume2,Issue5, Latha Anju Netal., International Journal of Advance Research, Ideas and Innovations in Technology, 2016.
- [6]<https://www.elprocus.com/passive-infrared-pir-sensor-with-applications>
- [7]<https://www.arrow.com/en/research-and-events/articles/ultrasonic-sensors-how-they-work-and-how-to-use-them-with-arduino>
- [8]<https://www.elprocus.com/mq-135-alcohol-sensor-circuit-and-working>